

## PRODUCT DESCRIPTION



WTM190TL-NT is an open frame LED professional monitor. It offers wide viewing angles and clear, crisp images. Its slim design makes self-service equipment more aesthetic, and its various of installation ways make components integrating much more easier.

Typical Application:

Amusement and Entertainment Equipment, KIOSK, Self service Terminal, Interactive Digital Signage, VTM and Way-finding machine, etc.

## ADVANTAGES

### Easy to Deploy

Plug-and-play. Adapts to universal power :12V DC

### Durable and Professional Design

All metal structure, sleek & elegant design, that makes the product durable and stable

### Working all around the clock

High quality components to ensure the product reliability

### Flexible Installation

VESA mount, heavy-duty stand gives you a choice of fixed or desktop mounting

### High Definition LCD Panel

Full HD 1280 x 1024 resolution

### TECHNICAL SPECIFICATIONS LCD

#### > LCD Panel

Backlight	LED
Brightness	250 cd/m <sup>2</sup>
Contrast Ratio	1000:1
Viewing Angle	H:170° / V:160°
Response Time	5 ms (GTG)
Supported Colors	16.7M Colors
Display Resolution	1280 x 1024 (4:3)
Display Frame Rate	60Hz
Input Resolution	1280 x 1024 @ 60Hz (Analog) 1280 x 1024 @ 60Hz (Digital)
Connector	1x VGA /1x DVI /1x HDMI
<b>&gt; Mechanical</b>	
Dimensions	422.8 x 347.5 x 47.1 mm
Package Dimension	531 x 155 x 473 mm

Weight(approximately)	6 kg / 8 kg
Wall Mount Type	VESA,MIS-D,100,C

#### > OSD Functions

OSD Control	Push Button
OSD Language	English, Chinese

#### > Electrical

Power Supply	DC in: DC 12V (50/60 Hz)
Normal Operation	≤ 21W (typ.)
Power Off	≤ 2 W (typ.)

Internal Speaker	no
------------------	----

#### > Environmental

Operation	0 °C ~ 40 °C, 90% RH
Storage	-20 °C ~ 60 °C, 90% RH

#### > Options

Other	Wall mounts, Desktop base
-------	---------------------------

#### Shanghai Headquarter



TEL: +86 (0)21-58361091  
400-621-1510

ADD: Room 6206-6207, Building 6, NO.1687 Changyang Road, Yangpu District ,Shanghai, China

#### Beijing Office



TEL: +86 (0) 10-81786110

ADD: Room 1001,Unit 5,Building 2, Tiantongyuan North Second District,Changping District,Beijing,China



Learn more at: [www.any-touch.com](http://www.any-touch.com) ,email us at: [sales@any-touch.com](mailto:sales@any-touch.com)  
Specifications subject to change without notice.  
Copyright © 2017 Anytouch Technologies Co., LTD



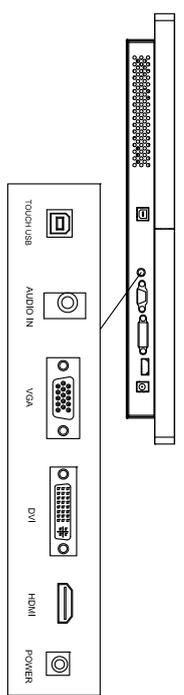
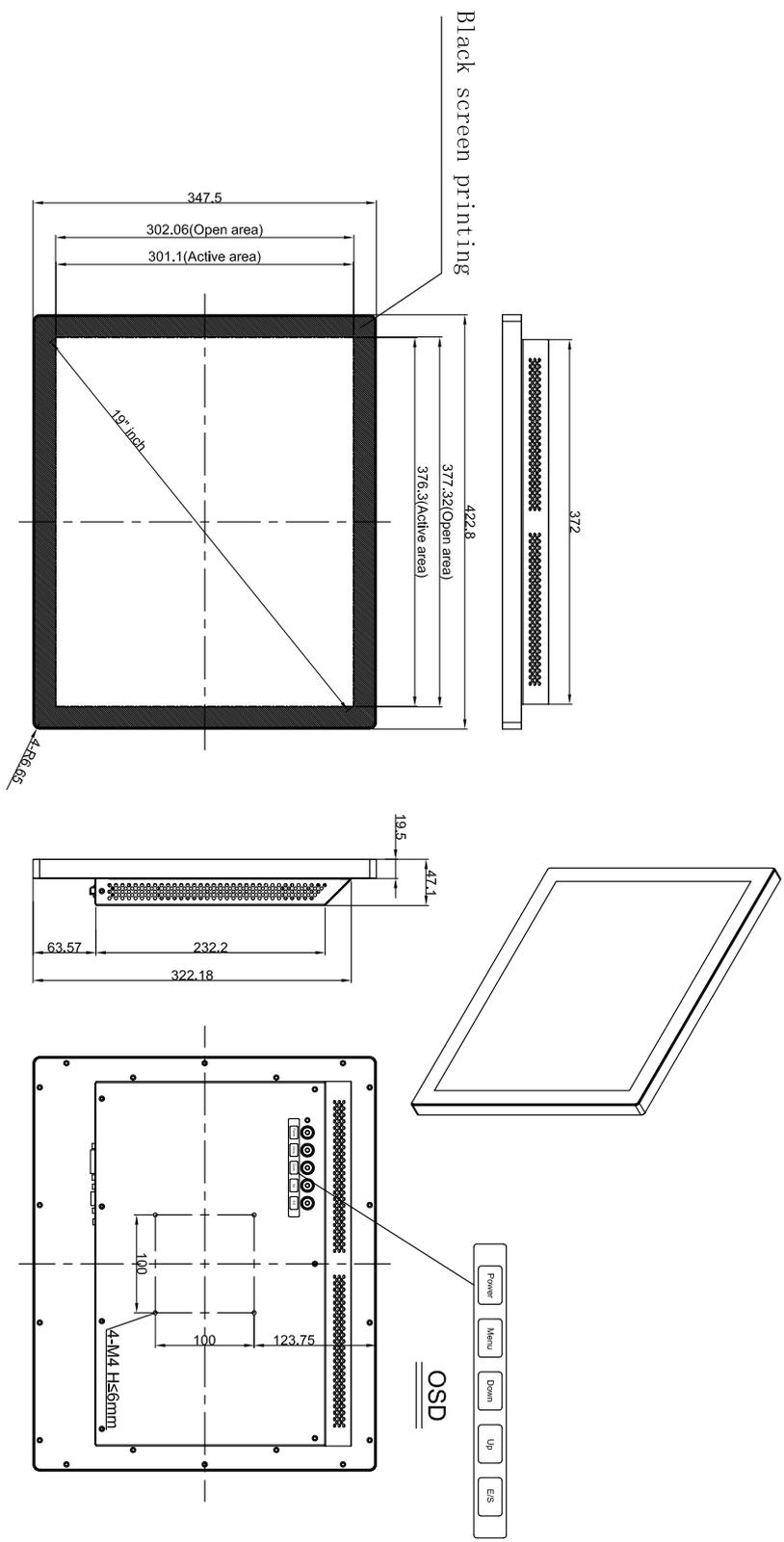

Tolerance Table	
Dimension Range	Tolerance(mm)
Under 25 mm	0.1
25-100 mm	0.2
100-1-250 mm	0.4
250-1-400 mm	0.8
400-1-500 mm	1.5
500-1-630 mm	2.0
630-1-800 mm	2.5

**TOLERANCING**

UNLESS OTHERWISE SPECIFIED ALL DIMS ARE mm

X ±0.2      RADIUS ±0.15

XX ±0.1      ANGLES ±0.5°

DO NOT SCALE DRAWING

Title: **WTM190-CU**

Date: 2017.12.13

Scale: NTS

Sheet: 1 of 1

Rev

Date

Description

By

